

X1-Micro 4 in 1

**1300 W / 1500 W / 1600 W /
1800 W / 2000 W / 2200 W**

Installation Manual

Version 4.0

www.solaxpower.com











©Refer to the QR code or at
<http://kb.solaxpower.com/>

Safety

1. Contents may be periodically updated or revised. SolaX reserves the right to make improvements or changes in the product(s) and the program(s) described in this manual without the prior notice.
2. The installation, maintenance and grid-related setting can only be performed by qualified personnel who:
 - Are licensed and/or satisfy state and local jurisdiction regulations;
 - Have good knowledge of this manual and other related documents.
3. Before installing the device, carefully read, fully understand and strictly follow the detailed instruction of the user manual and other related regulations. SolaX shall not be liable for any consequences caused by the violation of the storage, transportation, installation, and operation regulations specified in this document and the user manual.
4. Use insulated tools when installing the device. Individual protective tools must be worn during installation, electrical connection and maintenance.
5. Please visit the website www.solaxpower.com of SolaX for more information.

Descriptions of Labels

	CE mark of conformity		Caution, risk of danger
	Caution, risk of electric shock		Caution, hot surface
	Read the enclosed documentations		Do not dispose of the inverter together with household waste.
	ANATEL certification		TUV certification
	Danger of high voltage. Do not touch live parts for 5 minutes after disconnection from the power sources.		

DANGER!

Lethal danger from electrical shock due to the inverter

- Only operate the inverter when it is technically faultless. Otherwise, electric shock or fire may occur.
- Do not open the enclosure in any case without authorization from SolaX. Unauthorized opening will void the warranty and cause lethal danger or serious injury due to electric shock.

DANGER!

Lethal danger from electrical shock due to the PV

- Never touch the positive or negative pole of PV connecting device. Touching both of them at the same time is prohibited as well.
- Do not ground the positive or negative pole of the PV modules.
- Only qualified personnel can perform the wiring of the PV panels.

WARNING!**Risk of personnel injury or inverter damage**

- During operation, do not touch any parts including the enclosure lid of the inverter.
- Never connect or disconnect the AC or DC connectors when the microinverter is running.
- Make sure that the input DC voltage \leq Maximum DC input voltage of the inverter. Overvoltage may cause permanent damage to the inverter, which is NOT covered by the warranty.
- The installation place should be away from humid or corrosive substance. Avoid installation near extremely hot/cold environment.
- Make sure that the microinverter is installed under the PV module in case of direct exposure to UV, rain and other harmful weather events.
- The front side of the microinverter needs to be installed facing the PV module. Avoid mounting the microinverter upside down.
- Avoid matching microinverters to cables that have been exposed to wet conditions.
- Avoid connecting batteries or other sources of power supply to each input of the microinverter, as each input is connected to one PV module.

CAUTION!

- Keep children away from the inverter.
- Only with permissions of local utility grid company, the microinverter can be connected to the grid.
- The installer must provide Over Current Protection Devices (OCPD) and external disconnect switches.

NOTICE!

- If an external RCD is required by local regulations, check which type of RCD is required for relevant electric codes. Values of Type A or Type AC RCD should refer to local requirements.
- All the product labels and nameplate on the inverter shall be maintained clearly visible.
- Comply with local safety rules and regulations before all electrical installations.

Scan the following QR code to acquire Safety Regulations in multiple languages:



Packing List

Including in the box:

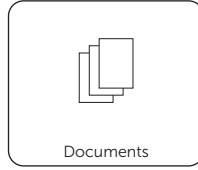
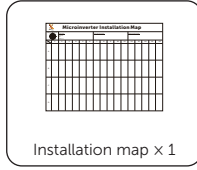
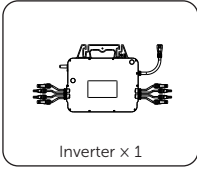

Sold separately:

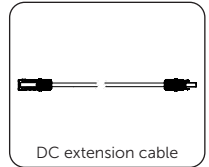
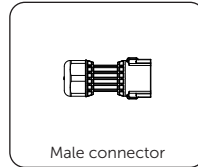
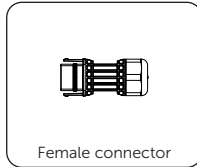
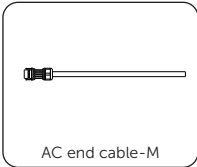
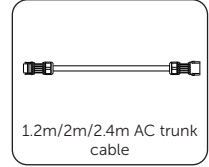
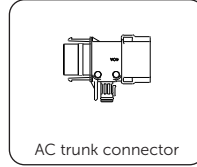
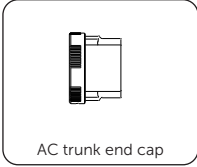

* Refer to the actual delivery for the optional accessories. The quantity of materials in the packing list above is the recommended quantity for one microinverter. If you need to install multiple microinverters, the actual situation prevails.

Installation Site

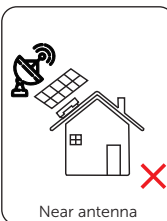
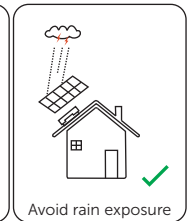
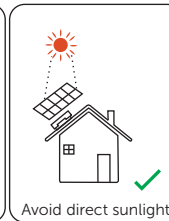
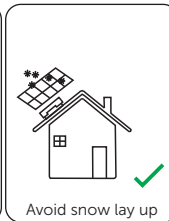
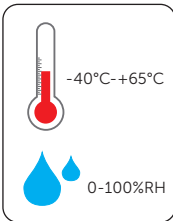

NOTICE!

- For outdoor-installation, precautions against direct-sunlight, rain -exposure and snow-accumulation are-recommended.
- Exposure to direct sunlight raises the temperature inside the device. This temperature rise poses no safety risks, but-may impact the device performance.

Installation Angle

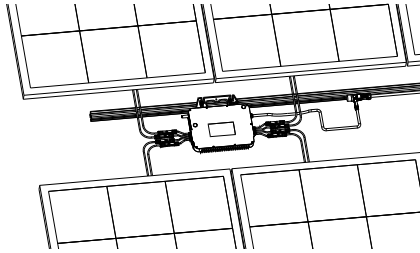

Parallel to the rail

Microinverter should be placed beneath the PV modules

Installation Tools

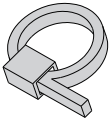

Cable tie

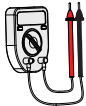

Multimeter

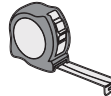

Measuring tape



Utility knife



Marker

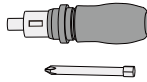

Torque screwdriver
(Phillips head: M4)

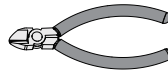

Diagonal pliers

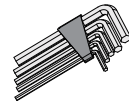

Allen key

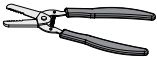

Wire stripper

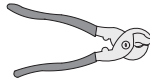

Wire cutter

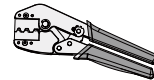

Crimping tool for PV
terminal



Safety gloves



Safety boots



Safety goggles

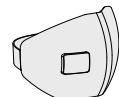

Anti-dust mask

Additionally Required Materials

No.	Required Material	Requirements
1	AC circuit breaker	Current: 50A for 10 AWG/40 A for 12 AWG (If there are additional safety regulations, please refer to the local safety regulations)
2	Guide rail	According to actual needs
3	Sliding block	Matching with the guide rail
4	Screw	Matching with the guide rail
5	AC cable	4-6 mm ² ; three-core soft wire cable

AC Branch Circuit Capacity

X1-Micro 1300/1500/1600/1800/2000/2200 can be used with the provided AC Trunk Cable and AC Trunk Connectors. The maximum number of microinverters on each AC branch is listed as follows:

	X1-Micro 1300	X1-Micro 1500	Maximum over current protection device
Maximum number per 10AWG branch	4@220V 4@230V 5@240V	4@220V 4@230V 4@240V	50 A
Maximum number per 12AWG branch	3@220V 3@230V 4@240V	3@220V 3@230V 3@240V	40 A
	X1-Micro 1600	X1-Micro 1800	Maximum over current protection device
Maximum number per 10AWG branch	4@220V 4@230V 4@240V	3@220V 3@230V 3@240V	50 A
Maximum number per 12AWG branch	3@220V 3@230V 3@240V	2@220V 2@230V 3@240V	40 A
	X1-Micro 2000	X1-Micro 2200	Maximum over current protection device
Maximum number per 10AWG branch	3@220V 3@230V 3@240V	3@220V 3@230V 3@240V	50 A

	X1-Micro 2000	X1-Micro 2200	Maximum over current protection device
Maximum number per 12AWG branch	2@220V 2@230V 2@240V	2@220V 2@230V 2@240V	40 A

Note:

An AC branch can connect to 1 in 1/2 in 1/4 in 1 microinverters at the same time, provided that the total current is less than the AC branch circuit capacity stipulated in local rules and regulations.

How many microinverters that each AC branch can connect depends on the current-carrying capacity of the cable.

Appearance and Dimensions

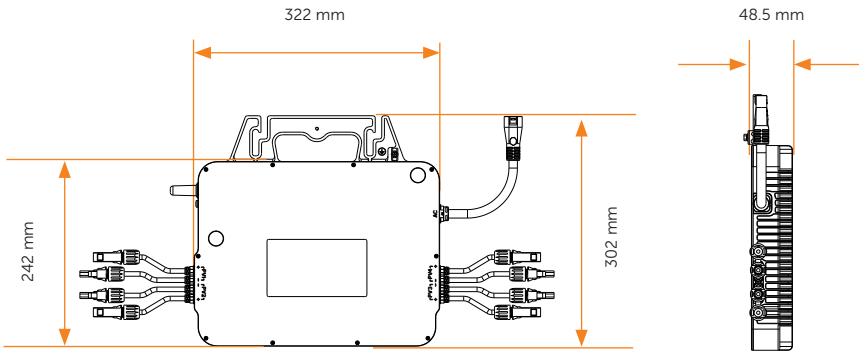

Terminal Description

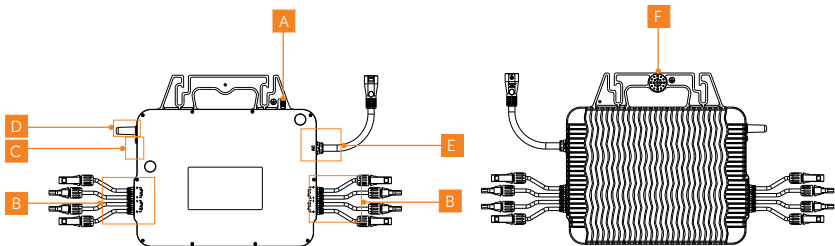

No.	Item	Description
A	Spare ground cable clip	For standby earth connection.
B	PV terminal	For PV connection.
C	Indicator	Show the status of the device.

No.	Item	Description
D	Antenna	To receive and transmit WiFi signal.
E	AC terminal	For AC connection.
F	Earth lug	A connection component for electrical devices which need grounding (perferred grounding method).

Mechanical Installation

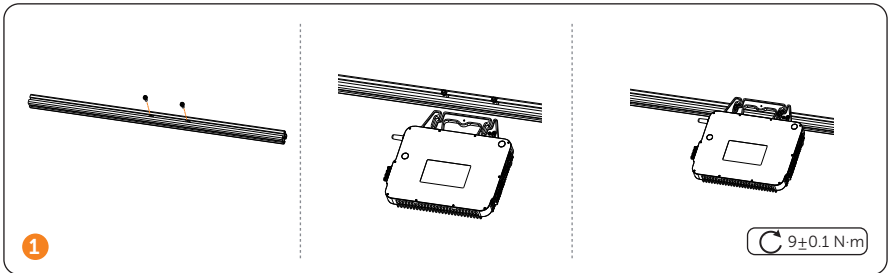

NOTICE!

- Choose the screwdriver according to the corresponding screws of the rail.
- Please use 4-6 mm² three core soft wire cable. Single core hard wire cable cannot be used in the following steps.

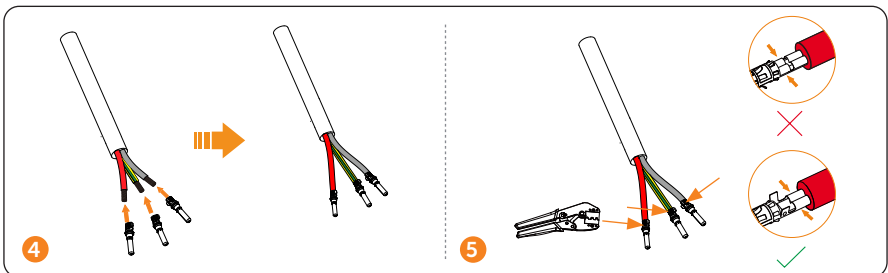
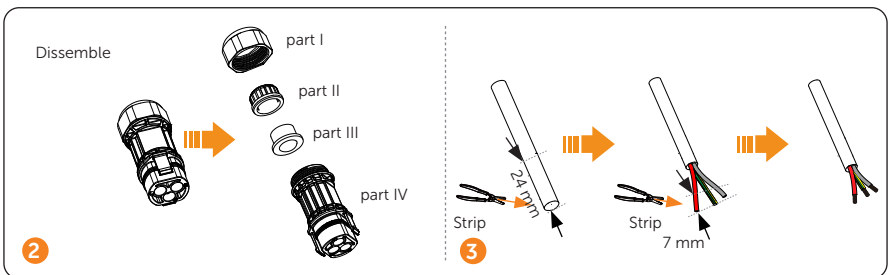

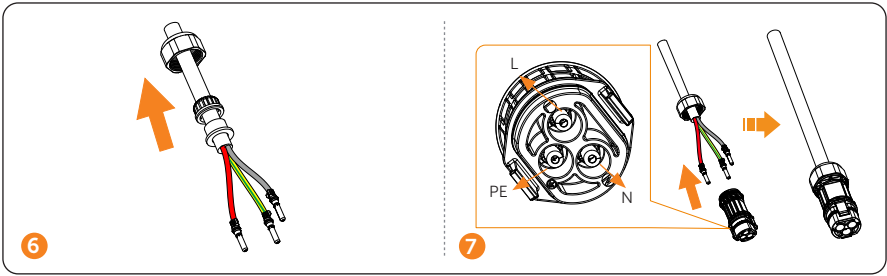

NOTICE!

- The connection between female connector and AC trunk cable is the similar to that of male connector. Connect female connector with female pin contact and install the female connector at the other side of AC trunk cable.

NOTICE!

- Choose the cable tie according to the rail width and the length of self-purchased accessories.
- Avoid placing AC connectors nearby any drainage channels.
- AC trunk connectors should be placed nearby the AC cable of microinverters.
- Select the AC cable with an appropriate length according to the actual installation situation

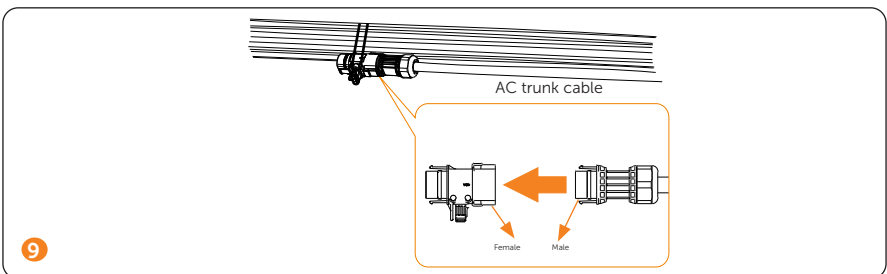
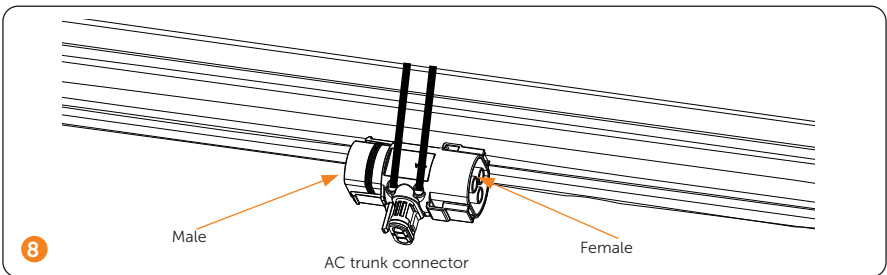

NOTICE!

- In order to better fix the AC trunk cable, it is recommended to use more cable ties to band the AC trunk cable.

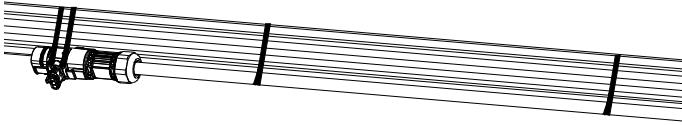

10

NOTICE!

- When connecting AC cables in the middle, please follow the diagram below.

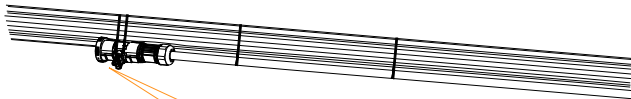
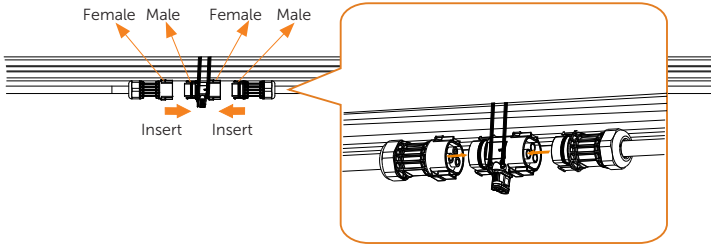

11

NOTICE!

- The male head of the AC trunk connector connected to the first microinverter needs to be connected with the AC Trunk End Cap.

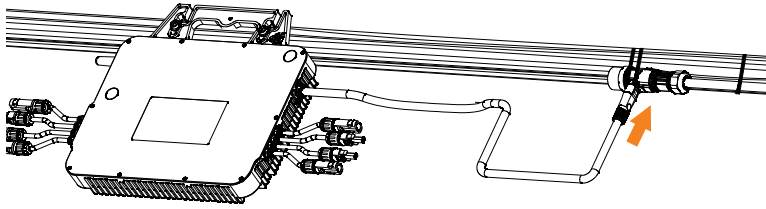

12

NOTICE!

- If you need to disconnect the AC connector from the AC cable, use the AC Trunk Port Disconnect Tool (see packing list).

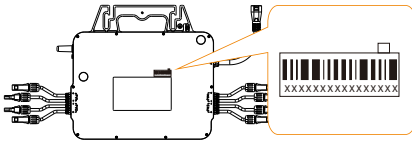

13

Microinverter Installati

Model: _____ Serial: _____ Customer information: _____
 Date: _____ Site: _____ Sheet of: _____

	1	2	3	4	5	6	7	8	9	10
A	 XXXXXXXXXXXXXXXXXXXX									
B										

PE Connection

NOTICE!

- Choose the suitable grounding method according to local safety regulations.

We provide two grounding methods for this series of microinverters. If the earth lug doesn't touch the rail or the rail is not on the ground, please try method 2.

Method 1 (major grounding method): Let the earth lug touch the rail.

Let the earth lug touch the rail

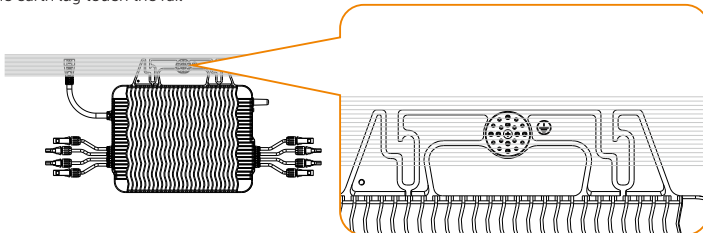

14

Method 2: Strip the PE cable, place the PE cable on the rail and fix it with screws.

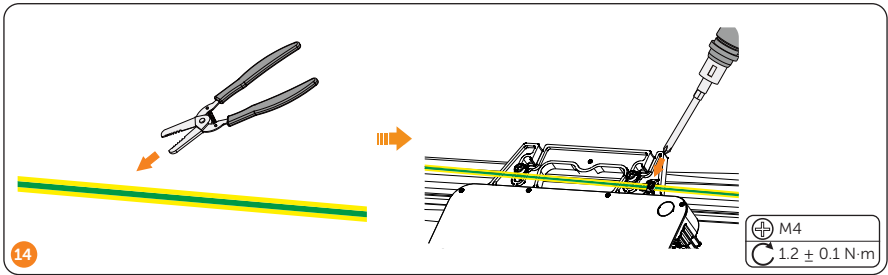

PV Connection

NOTICE!

- At least two or three trained and experienced workers are required to finish this step.

! WARNING!

- Please connect PV terminals in the correct way. Reverse connection may damage the microinverter!

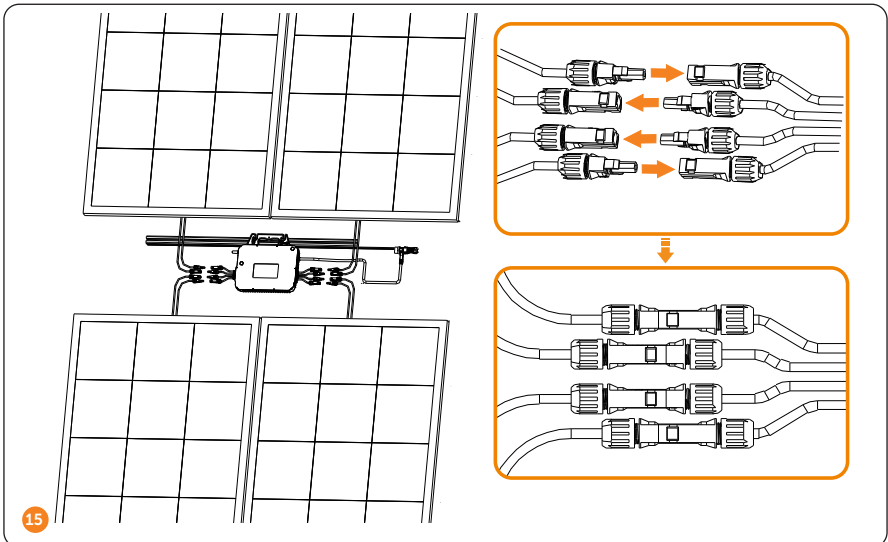

NOTICE!

- If the panels are too far from the microinverter, please use DC extension cable for connection.

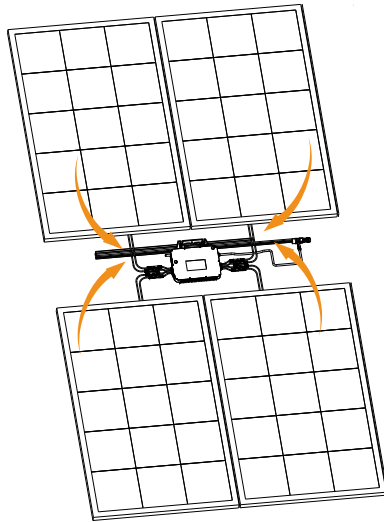

16 Cover the PV pannels

NOTICE!

- The length of AC end cable shall depends on the actual installation scene.

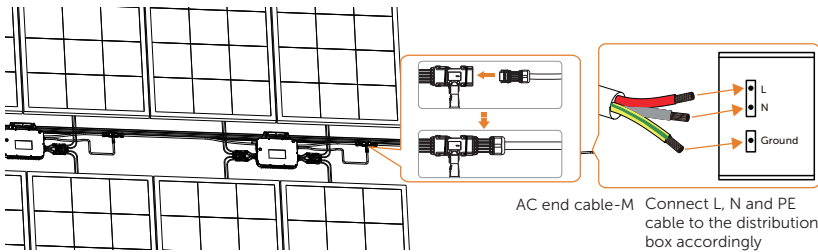

17

AC end cable-M Connect L, N and PE cable to the distribution box accordingly

NOTICE!

- If you didn't buy AC end cable-M, please follow the procedures below to make the wire before connecting to the distribution box.
- Please use 4-6 mm² three core soft wire cable. Single core hard wire cable cannot be used in the following steps.

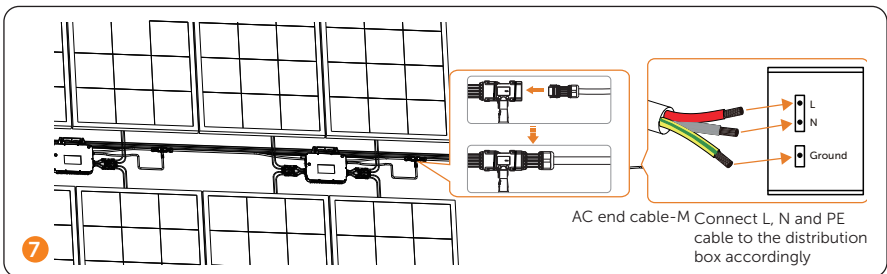
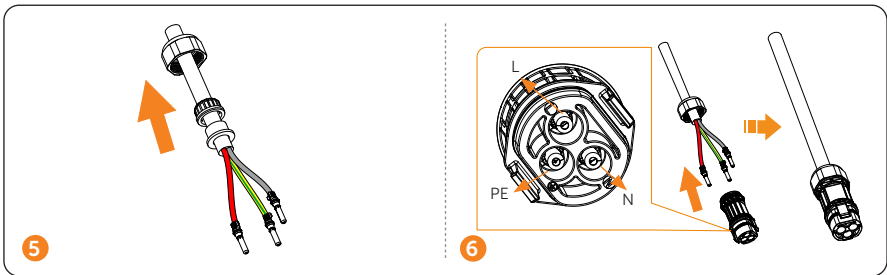
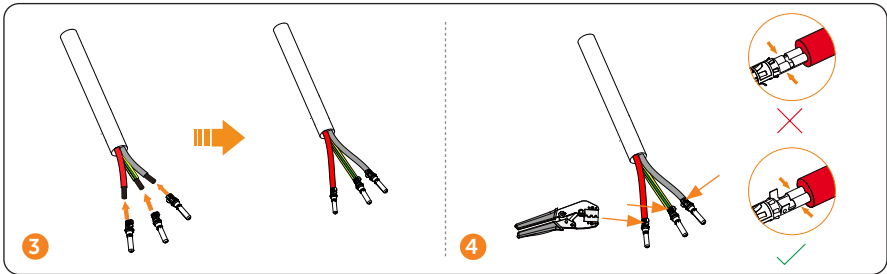
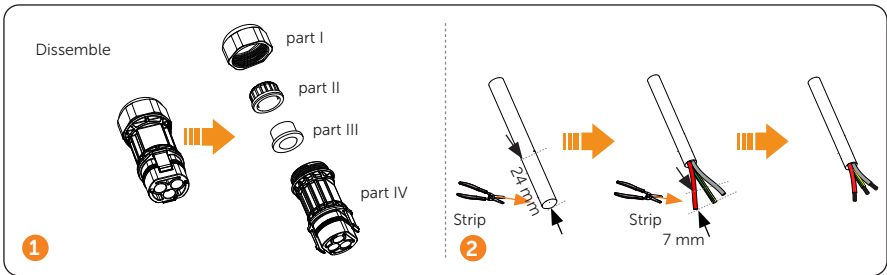

Power on the System

Step 1: First turn on the AC breaker on the branch circuit and then the main AC breaker of the house.

Step 2: Wait for about 2 minutes until the system is initiated.

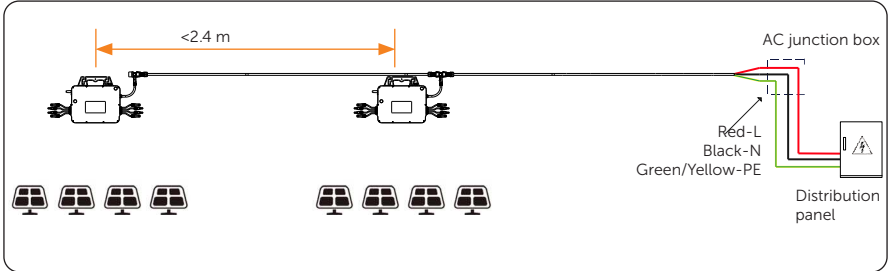

LED Indicator Status

LED Indicator Status	Description
Yellow light flash	Microinverter startup. If the light flashes once in 1s, flashes in 10s or still flashes after 10s, microinverter startup fails.
Yellow light steady on	Microinverter standby/self-checking.
Green light flash (5s)	Normal operation; normal AC grid; communicating with router.
Green light flash (2s)	Normal operation; normal AC grid; no connection with router.
Red light flash (2s)	No AC grid or AC grid outside the regulatory range.
Red light steady on	Error: non-grid abnormal fault. Machine fault like grounding detection fault and PV side fault.

About 10s after connection with DC power, the light turns yellow;

The yellow light flashes for 10s continuously and then keeps steady on which stands for microinverter self-check;

Afterwards, if the system is not powered on, the red light will flash, indicating for no grid existence;

After microinverter connects with DC power for the first time, red light flashes indicates for errors during microinverter startup.

Wi-Fi Configuration

Step 1: Scan the QR code below or search "SolaxCloud" to download the monitoring APP.



Step 2: Run the App, select the language, and touch [Sign up] at the bottom of Monitoring App.

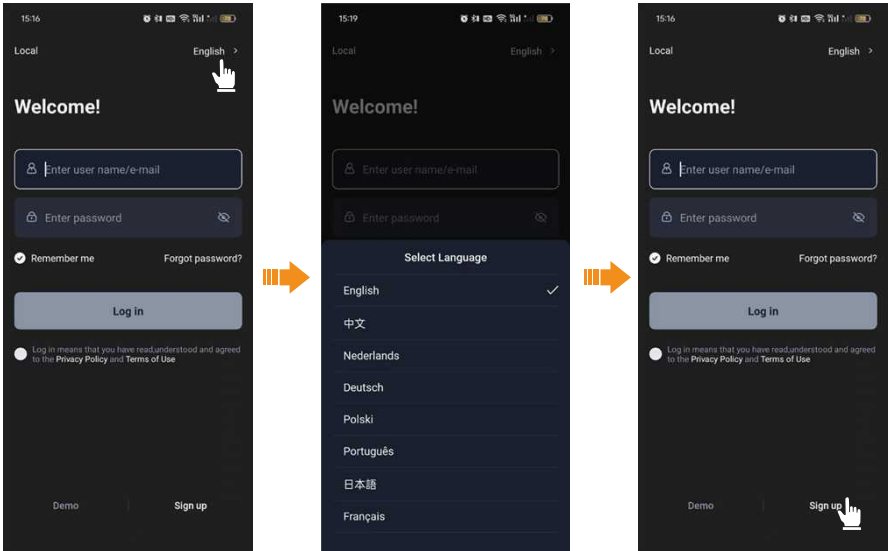

Step 3: Create the account. Log in the App after registration finished.

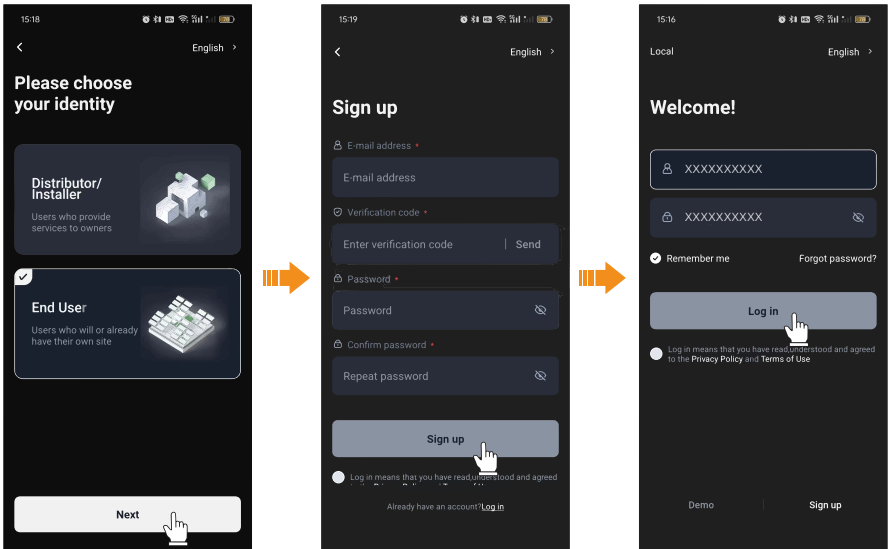

Step 4: Create a site by filling in the site information.

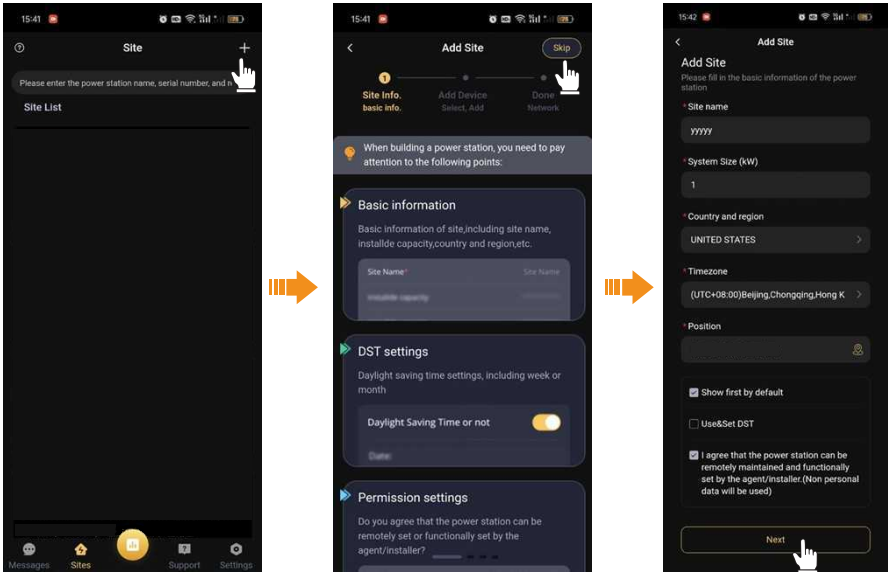

Step 5: Click [Microinverter], scan the QR code of microinverter to bind the device.

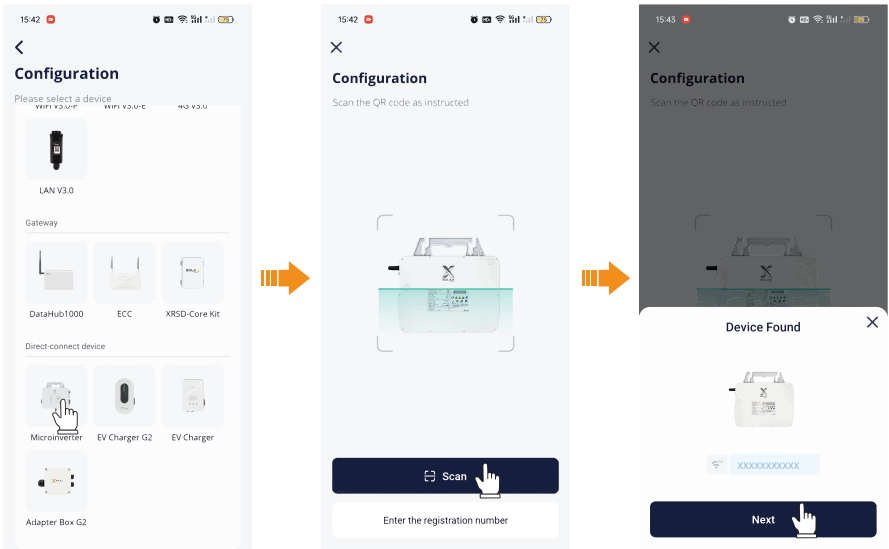

NOTICE

- If scanning the QR code step fails, then try to scan the one dimensional code. Scanning one dimensional code may lead to inaccurate scan results).

Step 6: Enter your WiFi account and password. Then, connect the device hotspot (name: Wifi_XXXXXXXXXX), start to configure the device network.

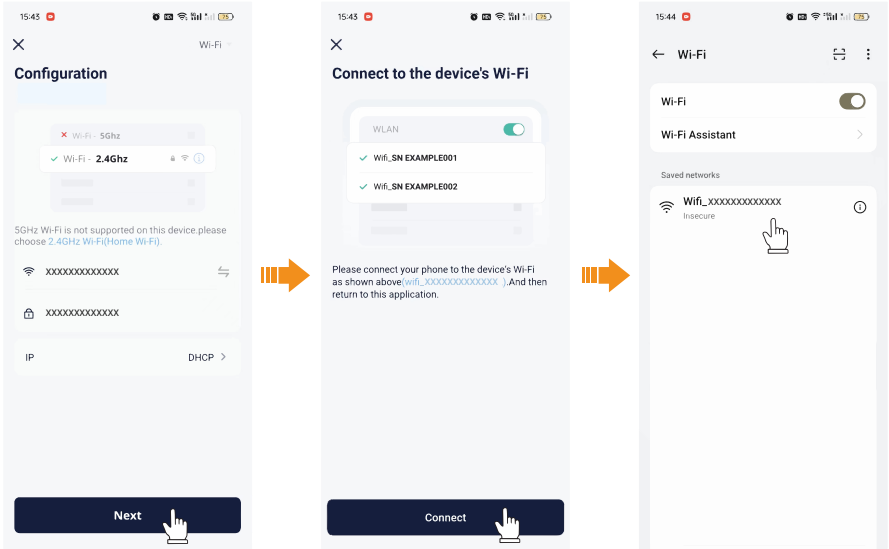

NOTICE!

- Before Network configuration, make sure the DC or AC side of the microinverter has been energized and the dongle module has been connected to "Upgrade/Dongle" port of the Microinverter .

Step 7: After configuration succeeds, please remember to change to your home WiFi for the following operations.

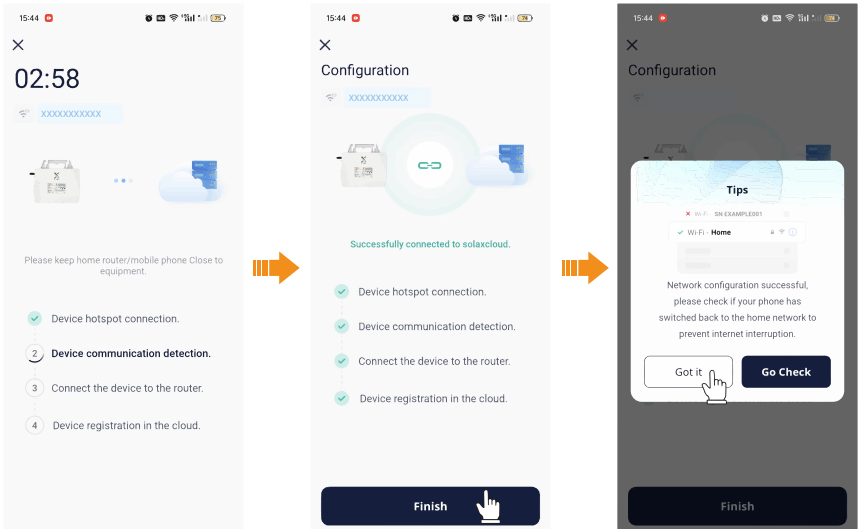

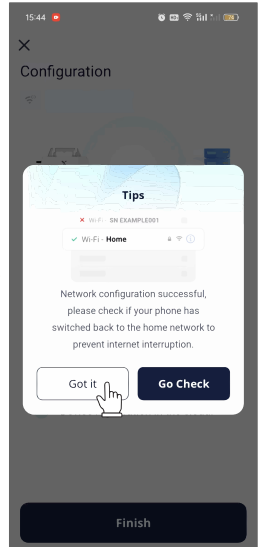
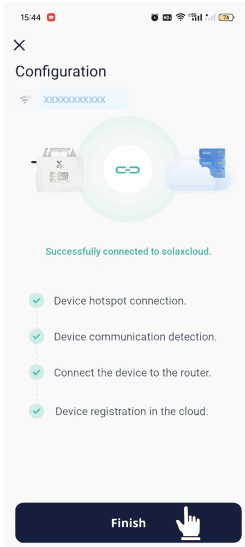
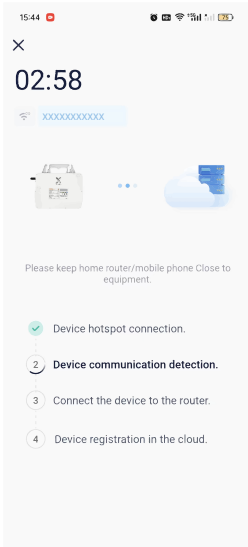

Step 8: Click [Layout] to customize your device layout and save the settings.

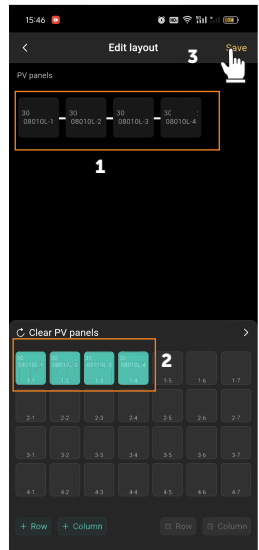
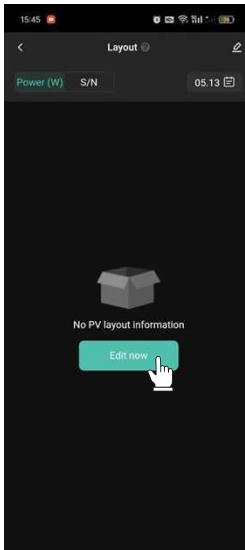
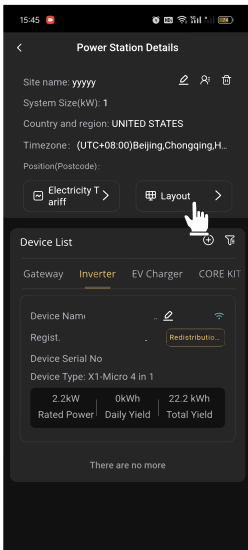

Step 9: Click the site to view your device detail information.

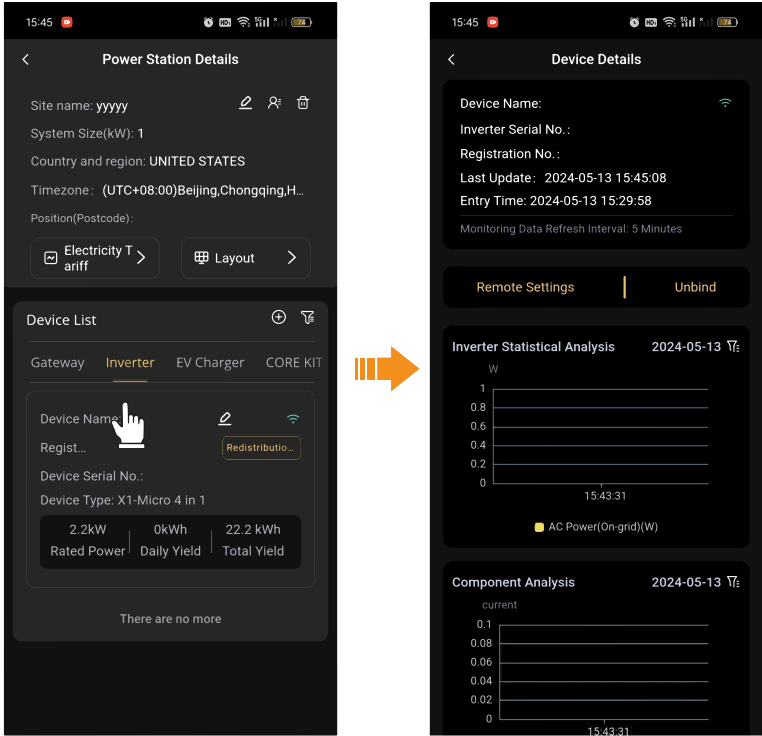

Technical Data

- DC Input

Model	X1-Micro 1300	X1-Micro 1500	X1-Micro 1600
Max. recommended DC power [W]	300 to 505+	320 to 540+	360 to 600+
Max. PV voltage [d.c. V]		60	
MPPT voltage range [d.c. V]		22-60	
Max. PV current [d.c. A]	4 × 12	4 × 14	4 × 15
Isc PV array short circuit current [d.c. A]	4 × 20	4 × 20	4 × 25
Max inverter backfeed current to the array [d.c.A]		0	
Start output voltage [d.c. V]	20	20	20
No. of MPPT trackers		4	
Strings per MPPT tracker	1	1	1

Model	X1-Micro 1800	X1-Micro 2000	X1-Micro 2200
Max. recommended DC power [W]	400 to 600+	400 to 670+	400 to 670+
Max. PV voltage [d.c. V]	60		
MPPT voltage range [d.c. V]	4 x 16	4 x 18	4 x 19.5
Max. PV current [d.c. A]	4 x 25	4 x 25	4 x 25
Isc PV array short circuit current [d.c. A]	4 x 30		
Max inverter backfeed current to the array [d.c.A]	0		
Start output voltage [d.c. V]	20	20	20
No. of MPPT trackers	4		
Strings per MPPT tracker	1	1	1

- AC Output

Model	X1-Micro 1300	X1-Micro 1500	X1-Micro 1600
Rated output apparent power [VA]	1300	1500	1600
Maximum continuous output power [VA]	1300	1500	1600
Nominal AC voltage [a.c. V] ¹	220 or 230 or 240 / 180-264		
Nominal AC frequency [Hz] ¹	50/60		
Maximum continuous output current [A]	5.91@220V	6.82@220V	7.28@220V
	5.66@230V	6.53@230V	6.96@230V
	5.42@240V	6.25@240V	6.67@240V
Power factor range	>0.99(-0.8~0.8 adjustable)		
Maximum units per 10 AWG branch ²	4@220V	4@220V	4@220V
	4@230V	4@230V	4@230V
	5@240V	4@240V	4@240V
Maximum units per 12 AWG branch ²	3@220V	3@220V	3@220V
	3@230V	3@230V	3@230V
	4@240V	3@240V	3@240V
Current inrush [a.c. A]	12		
Max output fault current [a.c. A]	16		
Max output overcurrent protection [a.c. A]	15		
Total harmonic distortion [%]	<3		

Model	X1-Micro 1800	X1-Micro 2000	X1-Micro 2200
Rated output apparent power [VA]	1800	2000	2200
Maximum continuous output power [VA]	1800	2000	2200
Nominal AC voltage [a.c. V] ¹	220 or 230 or 240 / 180-264		
Nominal AC frequency [Hz] ¹	50/60		
Maximum continuous output current [A]	8.19@220V	9.10@220V	10.00@220V
	7.83@230V	8.70@230V	9.57@230V
	7.50@240V	8.34@240V	9.17@240V
Power factor range	>0.99(-0.8~0.8 adjustable)		
Maximum units per 10 AWG branch ²	3@220V	3@220V	3@220V
	3@230V	3@230V	3@230V
	3@240V	3@240V	3@240V
Maximum units per 12 AWG branch ²	2@220V	2@220V	2@220V
	2@230V	2@230V	2@230V
	3@240V	2@240V	2@240V
Current inrush [a.c. A]	12		
Max output fault current [a.c. A]	16		
Max output overcurrent protection [a.c. A]	15		
Total harmonic distortion [%]	<3		

Note:

*1 Nominal AC voltage/frequency range may vary according to local rules and regulations.

*2 Refer to local rules and regulations for the specific number of microinverters per branch.

• **Efficiency, Standard and Environment Limit**

Model	X1-Micro 1300	X1-Micro 1500	X1-Micro 1600
Efficiency			
Nominal MPPT efficiency	99.5%		
Maximum efficiency	96.5%		
Night power consumption [mW]	<40		
Standard			
Safety	IEC62109		
EMC	IEC 61000, EN 62920, EN 301489, EN 55011		
Grid Connection Standard	IEC 61727, IEC 62116, EN 50549, VDE 4105, UNE217001, UNE217002, RD244/647, NTS Version 2.1 TYPE A, INMETRO, PEA/MEA		
Environment Limit			
Ingress protection rating	IP67		
Operating temperature range [°C]	-40 to 65 (> 45 Derating)		

Model	X1-Micro 1300	X1-Micro 1500	X1-Micro 1600
Humidity [%]	0 ~ 100(condensing)		
Storage temperature [°C]	-40 to 65		
Model	X1-Micro 1800	X1-Micro 2000	X1-Micro 2200
Efficiency			
Nominal MPPT efficiency	99.5%		
Maximum efficiency	96.5%		
Night power consumption [mW]	<40		
Standard			
Safety	IEC62109		
EMC	IEC 61000, EN 62920, EN 301489, EN 55011		
Grid Connection Standard	IEC 61727, IEC 62116, EN 50549, VDE 4105, UNE217001, UNE217002, RD244/647, NTS Version 2.1 TYPE A, INMETRO, PEA/MEA		
Environment Limit			
Ingress protection rating	IP67		
Operating temperature range [°C]	-40 to 65 (> 45 Derating)		
Humidity [%]	0 ~ 100(condensing)		
Storage temperature [°C]	-40 to 65		

- Generic Data

Model	X1-Micro 1300	X1-Micro 1500	X1-Micro 1600
Dimensions (W/H/D)[mm]	322 × 242 (302) × 48.5		
Net weight [kg]	6.2		
Heat dissipation treatment	Natural convection		
Monitoring ³	SolaXCloud		
Communication interface	Built-in Wi-Fi		
Model	X1-Micro 1800	X1-Micro 2000	X1-Micro 2200
Dimensions (W/H/D)[mm]	322 × 242 (302) × 48.5		
Net weight [kg]	6.2		
Heat dissipation treatment	Natural convection		
Monitoring ³	SolaXCloud		
Communication interface	Built-in Wi-Fi		

Note:

* 3 SolaX monitoring platform.

Contact Information



UNITED KINGDOM

- Unit C-D Riversdale House, Riversdale Road, Atherstone, CV9 1FA
- +44 (0) 2476 586 998
- service.uk@solaxpower.com



TURKEY

- Fevzi Çakmak mah. aslım cd. no 88 A Karatay / Konya / Türkiye
- service.tr@solaxpower.com



USA

- 3780 Kilroy Airport Way, Suite 200, Long Beach, CA, US 90806
- +1 (408) 690 9464
- info@solaxpower.com



POLAND

- WARSAW AL. JANA P. II 27. POST
- +48 662 430 292
- service.pl@solaxpower.com



ITALY

- +39 011 19800998
- support@solaxpower.it



PAKISTAN

- service.pk@solaxpower.com



AUSTRALIA

- 21 Nicholas Dr, Dandenong South VIC 3175
- +61 1300 476 529
- service@solaxpower.com.au



GERMANY

- Am Tullnaupark 8, 90402 Nürnberg, Germany
- +49 (0) 6142 4091 664
- service.eu@solaxpower.com
- service.dach@solaxpower.com



NETHERLANDS

- Twekkeler-Es 15 7547 ST Enschede
- +31 (0) 8527 37932
- service.eu@solaxpower.com
- service.bnl@solaxpower.com



SPAIN

- +34 9373 79607
- tecnico@solaxpower.com



BRAZIL

- +55 (34) 9667 0319
- info@solaxpower.com



SOUTH AFRICA

- service.za@solaxpower.com

Importer:

Authorised Representative (UK)

Name: SOLAX POWER UK LIMITED

Add: Unit C-D Riversdale House, Riversdale Road, Atherstone, CV9 1FA

Tel: +44 (0) 2476 586 998

E-mail: service.uk@solaxpower.com

Authorised Representative (AUS)

Name: SolaX Power AUS Pty Ltd

Add: 21 Nicholas Dr, Dandenong South VIC 3175

Tel: +61 1300 476 529

E-mail: service@solaxpower.com.au

Authorised Representative (EU)

Name: SolaX Power NL Company BV

Add: Twekkeler Es 15,7547 ST, Enschede, Netherlands

Tel: +31 (0)85 2737 932

E-mail: service.eu@solaxpower.com

Warranty Registration Form



For Customer (Compulsory)

Name _____ Country _____
Phone Number _____ Email _____
Address _____
State _____ Zip Code _____
Product Serial Number _____
Date of Commissioning _____
Installation Company Name _____
Installer Name _____ Electrician License No. _____

For Installer

Module (If Any)

Module Brand _____
Module Size(W) _____
Number of String _____ Number of Panel Per String _____

Battery (If Any)

Battery Type _____
Brand _____
Number of Battery Attached _____
Date of Delivery _____ Signature _____

Please visit our warranty website: <https://www.solaxcloud.com/#/warranty> or use your mobile phone to scan the QR code to complete the online warranty registration.



For more detailed warranty terms, please visit SolaX official website: www.solaxpower.com to check it.



SolaX Power Network Technology (Zhejiang) Co., Ltd.

ADD.: No. 278, Shizhu Road, Chengnan Sub-district, Tonglu County,
Hangzhou, Zhejiang, China
E-mail: info@solaxpower.com

Copyright © SolaX Power Network Technology (Zhejiang) Co., Ltd. All rights reserved.



320102118604